

First Team Sports, Inc.

Teammate Portable Player Bench

General Assembly Instructions

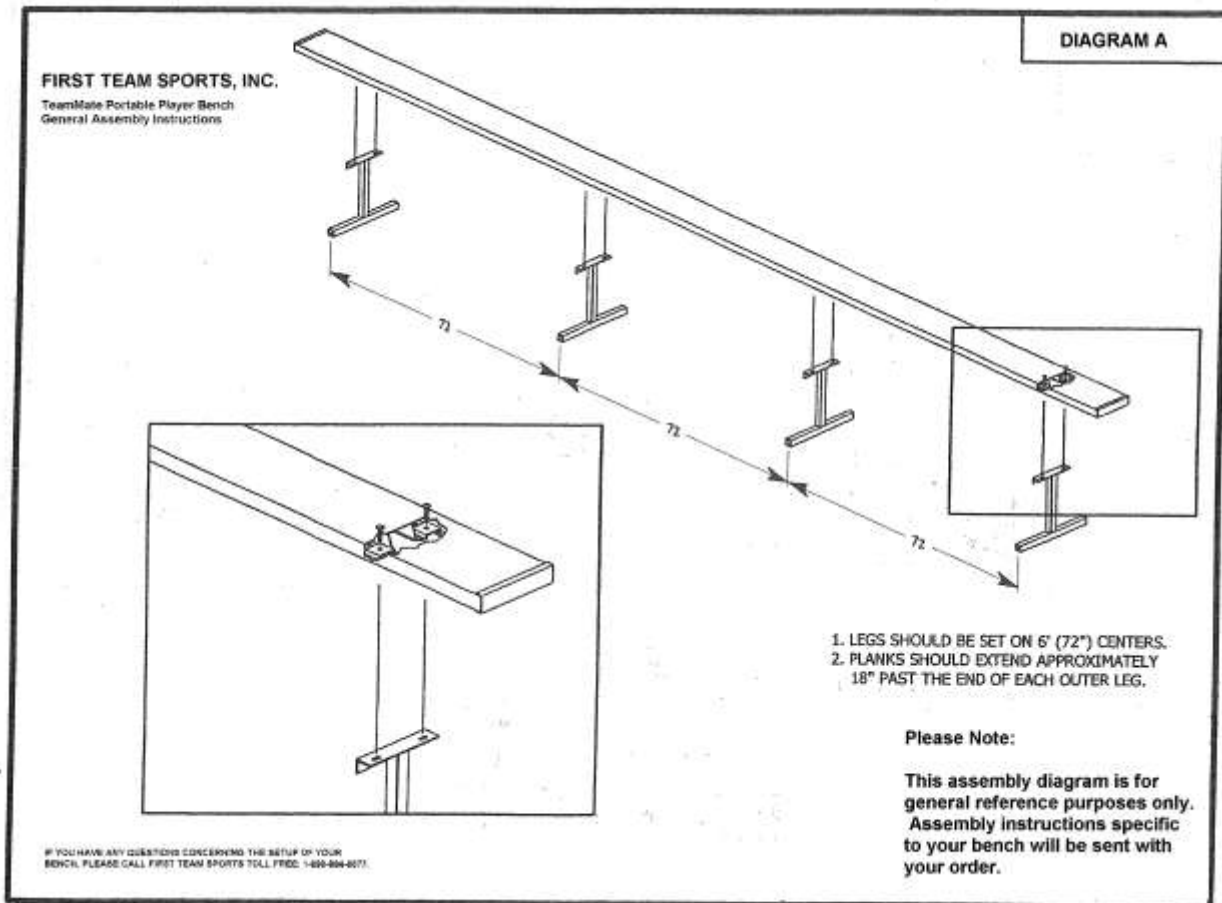

1. Lay seatplank face down on a working tabletop surface.
2. Using the seatclamps and 5/16" hardware provided. Loosely secure each leg to the seatplank as shown in diagrams A and B.
3. Space legs appropriately. Legs should be spaced on 72" centers with approx. 18" of seatplank outside the outermost legs. (The number of legs you receive will be based on the length of your bench)

4. Be sure seatclamps are positioned properly and tighten. PROPER SEATCLAMP POSITIONING IS CRUCIAL TO THE OVERALL STRENGTH OF THE ASSEMBLY. MAKE SURE SEATCLAMPS ARE CENTERED AND SQUARE, AS IN THE ILLUSTRATION IN DIAGRAM B.
5. When all bench legs are spaced properly and secured adequately, turn player bench upright and set on ground.
6. Assembly of your Teammate player bench is complete.

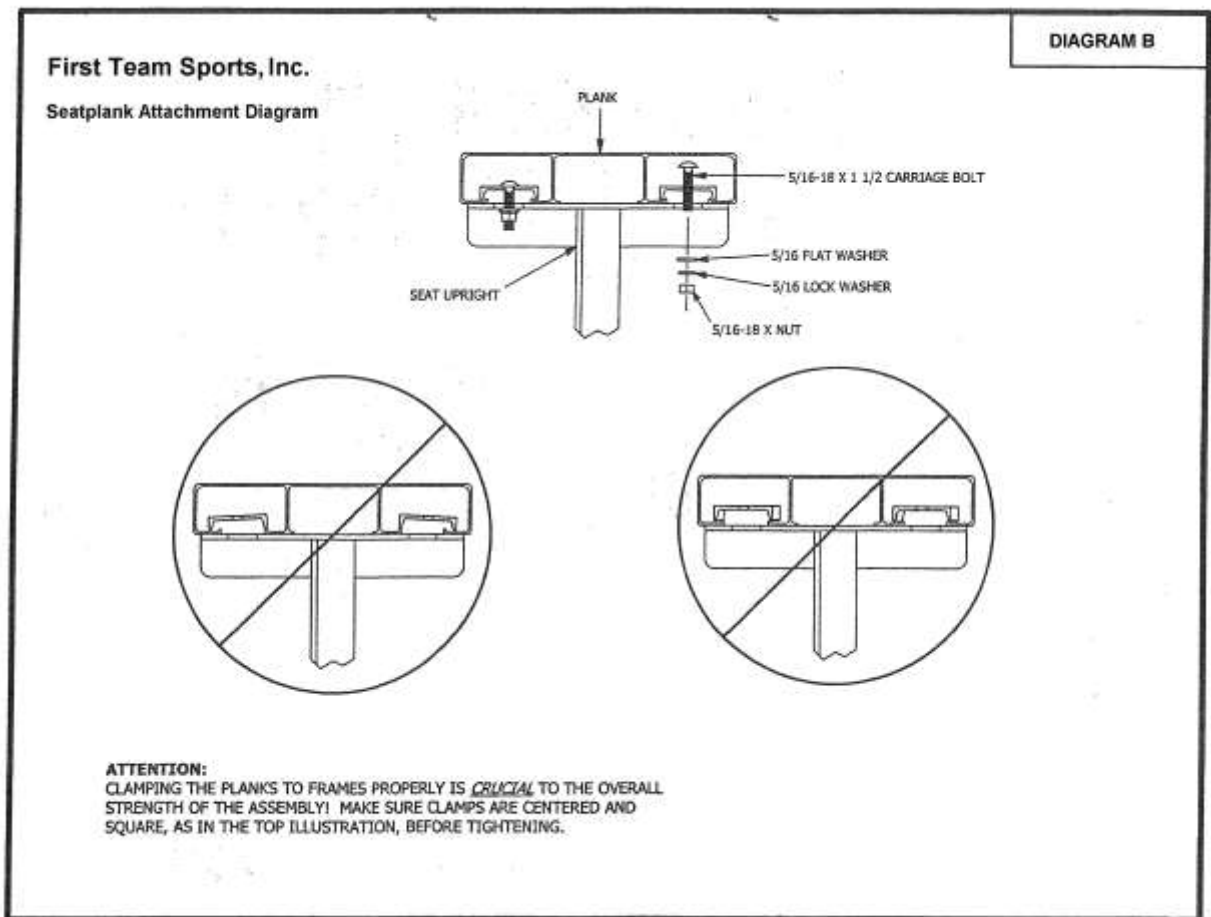

First Team Sports, Inc. * 902 Corey Road * Hutchinson, KS 67501 * 1-888-884-6677