

First Team Sports, Inc.

Teammate Fixed Player Bench with Backrest

General Assembly & Installation Instructions

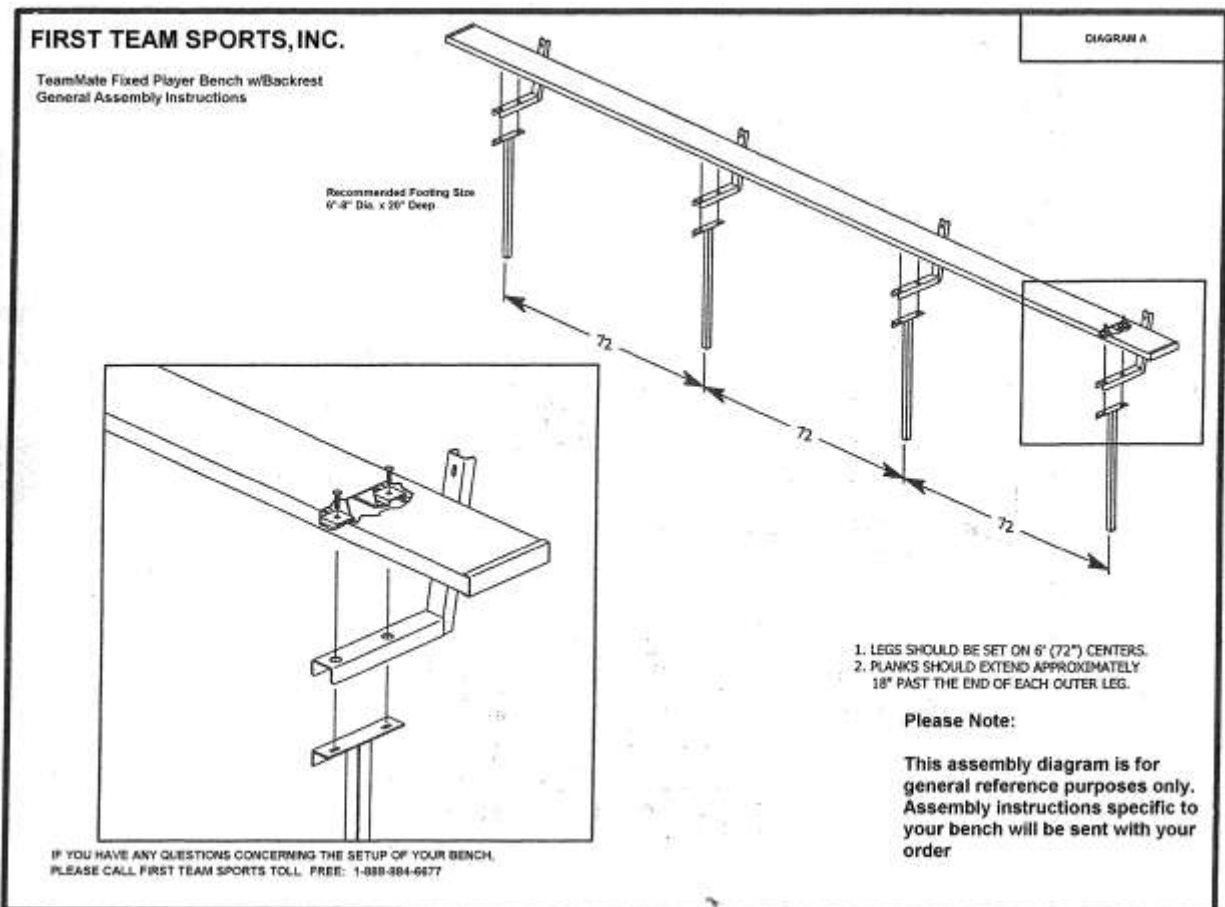

1. Lay seatplank face down on a working tabletop surface.
2. Using the seatclamps and 5/16" hardware provided. Loosely secure each leg and backrest support to the seatplank as shown in diagrams A and B. (Backrest supports are the "L" shaped pieces)
3. Space legs appropriately. Legs should be spaced on 72" centers with approx. 18" of seatplank outside the outermost legs. (The number of legs and backrest supports you receive will be based on the length of your bench)

4. Be sure seatclamps are positioned properly and tighten. PROPER SEATCLAMP POSITIONING IS CRUCIAL TO THE OVERALL STRENGTH OF THE ASSEMBLY. MAKE SURE SEATCLAMPS ARE CENTERED AND SQUARE, AS IN THE ILLUSTRATION IN DIAGRAM B.
5. When all bench legs and backrest supports are spaced properly and secured adequately, prop bench upright and proceed to step 6.
6. Following the procedures described above, secure backrest plank to backrest supports.
7. Determine proper location for bench installation.
8. When bench location has been determined, mark the location of each bench leg and dig a 20" deep hole at each spot. Each hole should be a minimum of 6"-8" in diameter.
9. Fill each hole with concrete and insert bench legs into footing holes.
10. Brace bench so bench is sitting straight and plumb with seatplank approximately 17" above ground level.
11. Let concrete cure for a minimum of 7 days before use.

